



- Ⓒ **GB** *Operating & Maintenance Instructions*
- Ⓒ **D** *Betriebsanleitung & Wartungsvorschriften*
- Ⓒ **DK** *Drifts- og vedligeholdelsesvejledning*
- Ⓒ **E** *Instrucciones de Mantenimiento & Operación*
- Ⓒ **F** *Instructions d'utilisation et de maintenance*
- Ⓒ **GR** *Οδηγίες Λειτουργίας & Συντήρησης*
- Ⓒ **I** *Istruzioni per l'uso e la manutenzione*
- Ⓒ **N** *Anvisninger for bruk og vedlikehold*
- Ⓒ **NL** *Gebruiksaanwijzing*
- Ⓒ **P** *Instruções de operação e de manutenção*
- Ⓒ **S** *Instruktionsbok*
- Ⓒ **SF** *Käyttö & Huolto-ohjeet*



Model 400000 | Intek
Extended Life Series

Model 440000 | Intek
Extended Life Series

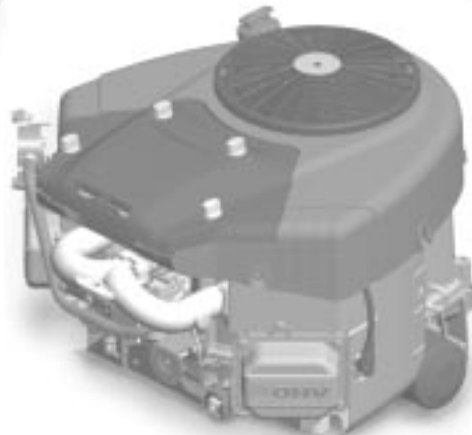

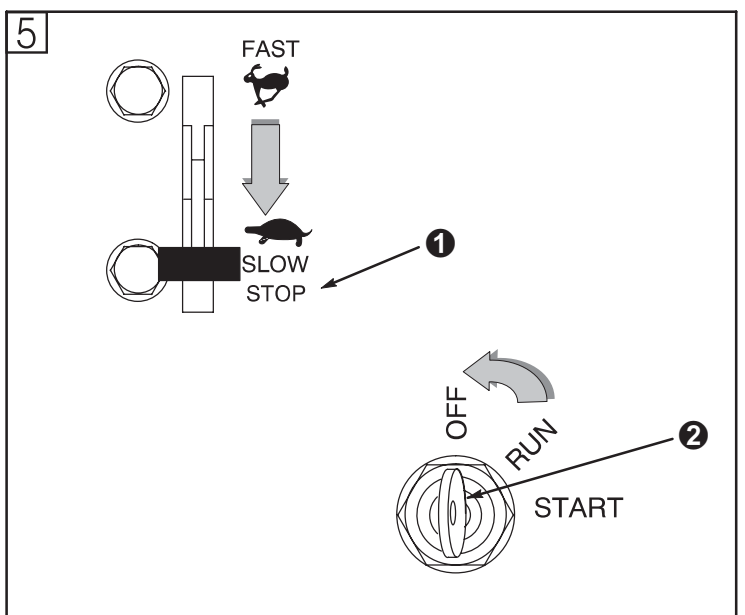
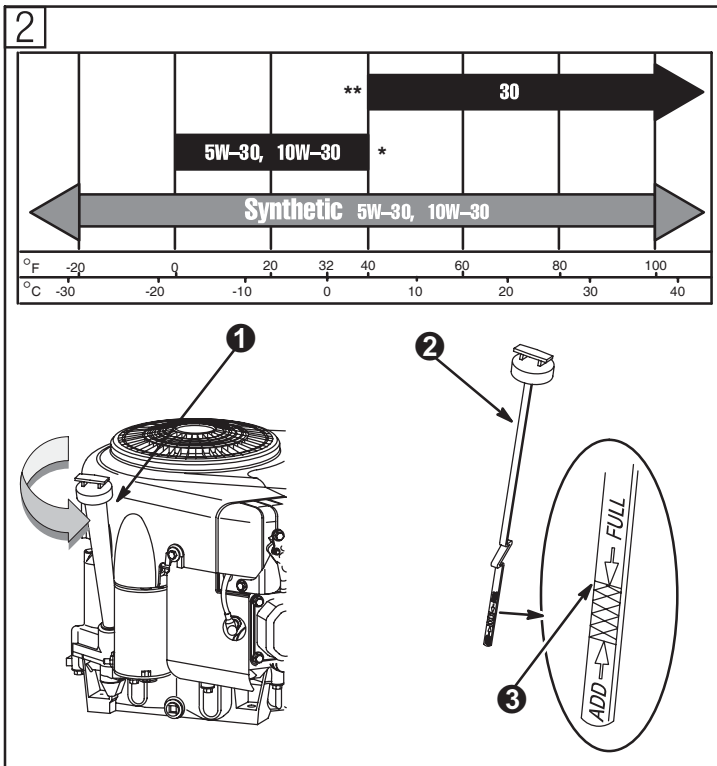
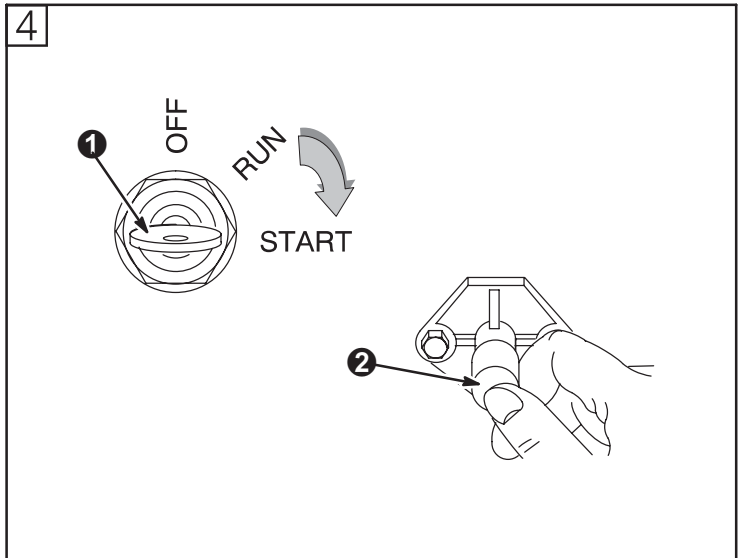
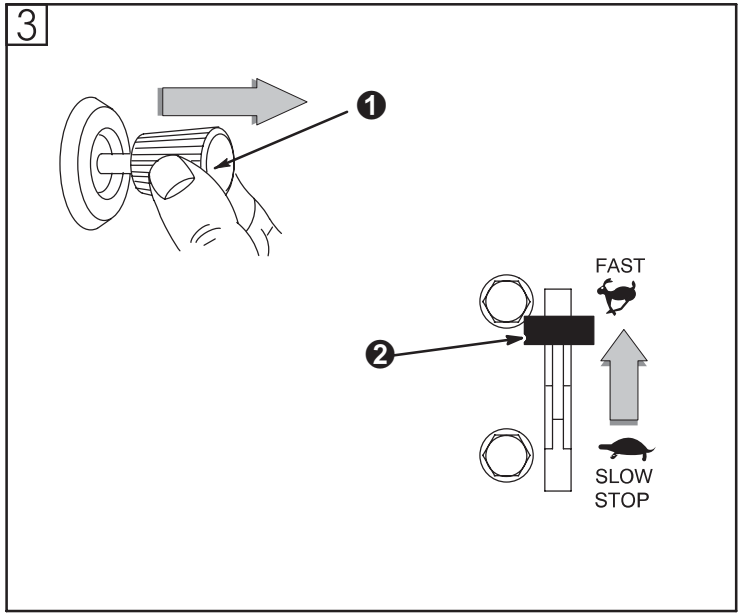
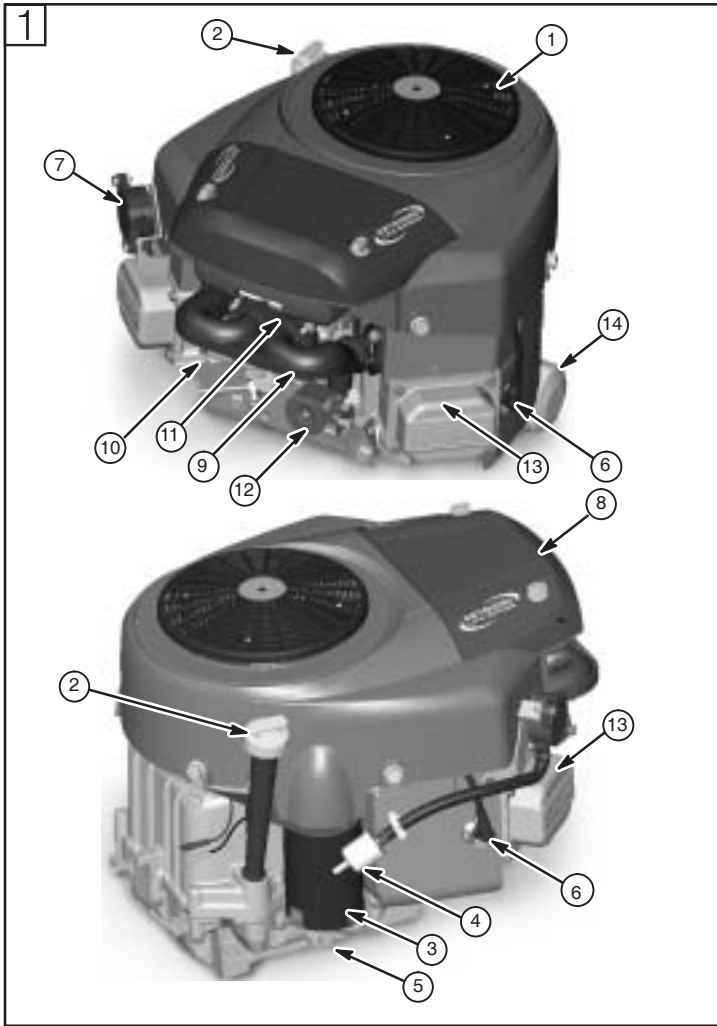

Note: (This note applies only to engines used in the U.S.A.) Maintenance, replacement or repair of the emission control devices and systems may be performed by any nonroad engine repair establishment or individual. However, to obtain no charge repairs under the terms and provisions of the Briggs & Stratton warranty statement, any service or emission control part repair or replacement must be performed by a factory authorized dealer.



How To Use Manual Figures

- ① - ⑨ refer to figures inside covers.
- ① - ⑱ refer to engine components in figure ①.
- ① - ⑨ refer to part/action in figures.

Record your engine Model, Type and Code numbers here for future use.

Record your date of purchase here for future use.

In the state of California, OHV Model 400000 and 440000 engines are certified by the California Air Resources Board to meet emissions standards for 250 hours. Such certification does not grant the purchaser, owner or operator of this engine any additional warranties with respect to the performance or operational life of this engine. This engine is warranted solely according to the product and emissions warranties stated elsewhere in this manual.

Technical Information

Engine Power Rating Information

The gross power rating for individual gas engine models is labeled in accordance with SAE (Society of Automotive Engineers) code J1940 (Small Engine Power & Torque Rating Procedure), and rating performance has been obtained and corrected in accordance with SAE J1995 (Revision 2002-05). Actual gross engine power will be lower and is affected by, among other things, ambient operating conditions and engine-to-engine variability. Given both the wide array of products on which engines are placed and the variety of environmental issues applicable to operating the equipment, the gas engine will not develop the rated gross power when used in a given piece of power equipment (actual "on-site" or net horsepower). This difference is due to a variety of factors including, but not limited to, accessories (air cleaner, exhaust, charging, cooling, carburetor, fuel pump, etc.), application limitations, ambient operating conditions (temperature, humidity, altitude), and engine-to-engine variability. Due to manufacturing and capacity limitations, Briggs & Stratton may substitute an engine of higher rated power for this Series engine.

Engine Components (see fig. ①)

- ① Rotating screen
- ② Oil fill/Dipstick
- ③ 12V electric starter
- ④ Fuel filter (if equipped)
- ⑤ Oil drain plug
- ⑥ Spark plug wire
- ⑦ Fuel pump
- ⑧ Air cleaner
- ⑨ Intake manifold
- ⑩ Choke control bracket
- ⑪ Carburetor
- ⑫ Throttle control bracket

⑬ Engine	Model	Type	Code
	xxxxxx	xxxx xx	xxxxxxxx

- ⑭ Oil filter

Hazard Symbols and Meanings

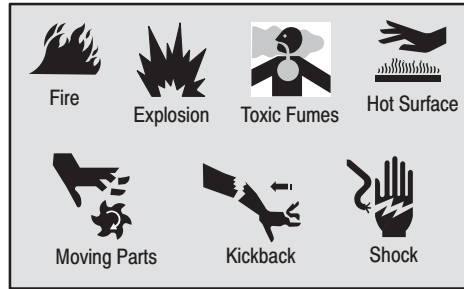

International Symbols and Meanings

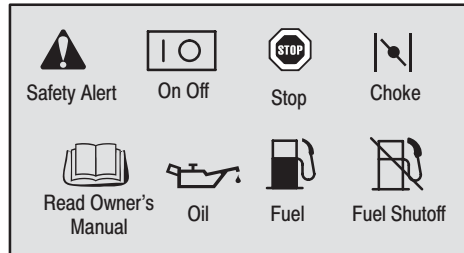

Safety Precautions

BEFORE OPERATING ENGINE

- Read entire Operating & Maintenance Instructions AND the instructions for the equipment this engine powers.*
- Failure to follow instructions could result in serious injury or death.

* Briggs & Stratton does not necessarily know what equipment this engine will power. For that reason, you should carefully read and understand the operating instructions for the equipment on which your engine is placed.

THE OPERATING & MAINTENANCE INSTRUCTIONS CONTAIN SAFETY INFORMATION TO

- Make you aware of hazards associated with engines
- Inform you of the risk of injury associated with those hazards, and
- Tell you how to avoid or reduce the risk of injury.

The safety alert symbol is used to identify safety information about hazards that can result in personal injury.

A signal word (DANGER, WARNING, or CAUTION) is used with the alert symbol to indicate the likelihood and the potential severity of injury. In addition, a hazard symbol may be used to represent the type of hazard.

DANGER indicates a hazard which, if not avoided, will result in death or serious injury.

WARNING indicates a hazard which, if not avoided, could result in death or serious injury.

CAUTION indicates a hazard which, if not avoided, might result in minor or moderate injury.

CAUTION, when used without the alert symbol, indicates a situation that could result in damage to the engine.

WARNING

The engine exhaust from this product contains chemicals known to the State of California to cause cancer, birth defects, or other reproductive harm.

WARNING

Gasoline and its vapors are extremely flammable and explosive.

Fire or explosion can cause severe burns or death.

WHEN ADDING FUEL

- Turn engine OFF and let engine cool at least 2 minutes before removing gas cap.
- Fill fuel tank outdoors or in well-ventilated area.
- Do not overfill fuel tank. Fill tank to approximately 1-1/2 inches below top of neck to allow for fuel expansion.
- Keep gasoline away from sparks, open flames, pilot lights, heat, and other ignition sources.
- Check fuel lines, tank, cap, and fittings frequently for cracks or leaks. Replace if necessary.

WHEN STARTING ENGINE

- Make sure spark plug, muffler, fuel cap and air cleaner are in place.
- Do not crank engine with spark plug removed.
- If fuel spills, wait until it evaporates before starting engine.
- If engine floods, set choke to OPEN/RUN position, place throttle in FAST and crank until engine starts.

WHEN OPERATING EQUIPMENT

- Do not tip engine or equipment at angle which causes gasoline to spill.
- Do not choke carburetor to stop engine.

WHEN TRANSPORTING EQUIPMENT

- Transport with fuel tank EMPTY or with fuel shut-off valve OFF.

WHEN STORING GASOLINE OR EQUIPMENT WITH FUEL IN TANK

- Store away from furnaces, stoves, water heaters or other appliances that have pilot light or other ignition source because they can ignite gasoline vapors.

 **WARNING**



Starting engine creates sparking.
Sparking can ignite nearby flammable gases.
Explosion and fire could result.

- If there is natural or LP gas leakage in area, do not start engine.
- Do not use pressurized starting fluids because vapors are flammable.

 **WARNING**



Engines give off carbon monoxide, an odorless, colorless, poison gas.
Breathing carbon monoxide can cause nausea, fainting or death.

- Start and run engine outdoors.
- Do not start or run engine in enclosed area, even if doors or windows are open.

 **WARNING**



Unintentional sparking can result in fire or electric shock.
Unintentional start-up can result in entanglement, traumatic amputation, or laceration.

BEFORE PERFORMING ADJUSTMENTS OR REPAIRS

- Disconnect spark plug wire and keep it away from spark plug.
- Disconnect battery at negative terminal (only engines with electric start).

WHEN TESTING FOR SPARK

- Use approved spark plug tester.
- Do not check for spark with spark plug removed.

 **WARNING**



Running engines produce heat. Engine parts, especially muffler, become extremely hot.
Severe thermal burns can occur on contact.
Combustible debris, such as leaves, grass, brush, etc. can catch fire.

- Allow muffler, engine cylinder and fins to cool before touching.
- Remove accumulated combustibles from muffler area and cylinder area.
- Install and maintain in working order a spark arrester before using equipment on forest-covered, grass-covered, brush-covered unimproved land. The state of California requires this (Section 4442 of the California Public Resources Code). Other states may have similar laws. Federal laws apply on federal land.

 **WARNING**



Rotating parts can contact or entangle hands, feet, hair, clothing, or accessories.
Traumatic amputation or severe laceration can result.

- Operate equipment with guards in place.
- Keep hands and feet away from rotating parts.
- Tie up long hair and remove jewelry.
- Do not wear loose-fitting clothing, dangling drawstrings or items that could become caught.

 **WARNING**



Rapid retraction of starter cord (kickback) will pull hand and arm toward engine faster than you can let go.
Broken bones, fractures, bruises or sprains could result.

- When starting engine, pull cord slowly until resistance is felt, then pull rapidly.
- Remove all external equipment/engine loads before starting engine.
- Direct coupled equipment components such as, but not limited to, blades, impellers, pulleys, sprockets, etc., must be securely attached.

Oil Recommendations (see fig. [2])

Engine shipped from Briggs & Stratton **without oil**. Before starting engine, fill with oil. Do not over-fill.

Use a high quality detergent oil classified "For Service SF, SG, SH, SJ" or higher such as Briggs & Stratton 30W, Part Number 100005 (20 oz.) or 100028 (48 oz.). Use no special additives with recommended oils. Do not mix oil with gasoline.

Choose the SAE viscosity grade of oil from this chart that matches the starting temperature anticipated before the next oil change. (see fig. [2])



Note: Synthetic oil meeting ILSAC GF-2, API certification mark and API service symbol (shown at left) with "SJ/CF ENERGY CONSERVING" or higher, is an acceptable oil at all temperatures. **Use of synthetic oil does not alter required oil change intervals.**

* Air cooled engines run hotter than automotive engines. The use of non-synthetic multi-viscosity oils (5W-30, 10W-30, etc.) in temperatures above 40° F (4° C) will result in higher than normal oil consumption. When using a multi-viscosity oil, check oil level more frequently.

** Use of SAE 30 oil below 40° F (4° C) will result in hard starting and possible engine damage due to inadequate lubrication.

Check oil level (see fig. [2])

Oil capacity is about 1.8 liters (60 ounces) if engine is not equipped with oil filter. Oil capacity is about 1.9 liters (64 ounces) if engine is equipped with oil filter.

Note: Oil capacity will be greater if engine is equipped with remote oil filter.

Place engine level and clean around oil fill ①.

Remove dipstick ②, wipe with clean cloth, insert and tighten down again. Remove dipstick and check oil level. Oil should be at FULL mark ③. If oil is required, add slowly. Tighten dipstick firmly before starting engine.

After filling with or changing oil, start and run engine at idle for 30 seconds. Shut engine off. Wait 30 seconds and check oil level. Check for oil leaks. Add oil, if required, to bring level to FULL mark on dipstick.

Fuel Recommendations

Use clean, fresh, regular lead-free gasoline with a minimum of 85 octane. Leaded gasoline may be used if it is commercially available and if unleaded is unavailable. Purchase fuel in quantity that can be used within 30 days. See **Storage**.

In U.S.A. leaded gasoline may not be used. Some fuels, called oxygenated or reformulated gasolines, are gasolines blended with alcohols or ethers. Excessive amounts of these blends can damage the fuel system or cause performance problems. If any undesirable operating symptoms occur, use gasoline with a lower percentage of alcohol or ether.

This engine is certified to operate on gasoline. Exhaust Emission Control System: EM (Engine Modifications). Do not use gasoline which contains Methanol. Do not mix oil with gasoline.

For engine protection, we recommend using Briggs & Stratton Fuel Stabilizer available from an Authorized Briggs & Stratton Service Dealer.

Check fuel level.



Before refueling, allow engine to cool 2 minutes.

Clean around fuel fill before removing cap to refuel. Remove cap. Fill tank to approximately 1-1/2 inches below top of neck to allow for fuel expansion. Be careful not to overfill.

Starting (see figs. [3] [4])



ALWAYS KEEP HANDS AND FEET CLEAR OF EQUIPMENT MOVING PARTS.



Do not use a pressurized starting fluid. Vapors are flammable.

Start, store and fuel lawn mower in level position. Start lawn mower on hard surface or over previously cut grass.

Check oil level.

Open fuel shut-off valve, if equipped.

Before starting engine (see fig. [3])

If engine runs low on oil, an **oil pressure switch** (if engine is equipped) will activate a warning light. (Read the operating instructions supplied by the equipment manufacturer.) See **Oil pressure**.

1. Open fuel shut-off valve, if equipped.
2. Move choke control to CHOKER position ①.

Note: If engine does not start, remove air cleaner to check choke. Choke must fully close. If not, see **Adjustments**.

3. Move throttle control ② to FAST position.

Electric starter (see fig. [4])

Turn key to START position ① or press button ②. Repeat if necessary with choke off and throttle control in FAST position. Operate engine with choke off and throttle in FAST position.

Note: If equipment manufacturer has supplied battery, charge it before trying to start engine, as equipment manufacturer recommends. Use short starting cycles (15 secs. per min.) to prolong starter life. Extended cranking can damage starter motor.

CAUTION: If engine is equipped with battery for electric starter, do not operate engine with battery disconnected.

Stopping (see fig. [5])

Do not move choke control to CHOKER to stop engine. Backfire or engine damage may occur. Move throttle control to IDLE or SLOW position, then to STOP ① or turn key to OFF ②.

Always remove key from switch when equipment is not in use or left unattended.



When engine or equipment is transported, close fuel shut-off valve, if equipped, to prevent fuel leakage.

Maintenance (see figs. [7] [8] [9])

Also, see **Maintenance Schedule**. Follow the hourly or calendar intervals, whichever occur first. More frequent service is required when operating in adverse conditions. See any Authorized Briggs & Stratton Dealer for correct replacement parts.



To prevent accidental starting, remove spark plug wire ① and ground it before servicing, and disconnect battery at negative terminal, if equipped.

Change oil level regularly.

Oil service (see fig. [7])

Be sure correct oil level is maintained. Check every 8 hours or daily, before starting engine. See oil filling procedure, **Oil Recommendations**.

Change oil.

Change oil after first 8 hours of operation. Change oil while engine is warm. Refill with new oil of recommended SAE viscosity grade. (see fig. [2])

Change oil filter ②

Replace oil filter after every 100 hours of operation or every season, whichever occurs first. Before installing new filter, lightly oil filter gasket with fresh, clean engine oil. Screw filter on by hand until gasket contacts oil filter adapter. Tighten 1/2 to 3/4 turn more. Start and run engine at IDLE to check for oil leaks. Stop engine. Recheck oil level and add oil if required.

Oil pressure

If oil pressure drops below 4-6 psi (.2-.4 kg/cm²), an oil pressure switch (if engine is equipped) will either activate a warning device or stop the engine. Check oil level with dipstick. If oil level is between **ADD** and **FULL** mark on dipstick, do not try to restart engine. Contact an Authorized Briggs & Stratton Service Dealer. Do not operate engine until oil pressure is corrected.

If oil level is below **ADD** mark on dipstick, add oil to bring level to **FULL** mark. Restart engine and check oil pressure. If pressure is normal, continue to operate engine.

Note: Oil pressure gauge, if engine is equipped, is supplied by manufacturer of equipment.

Spark plug service (see fig. [9])



DO NOT check for spark with spark plugs removed. Use only Briggs & Stratton Spark Tester ②, to check for spark.

DO NOT crank engine with spark plug removed. If engine is flooded, place throttle in FAST and crank until engine starts.

Spark plug gap ③ should be .76 mm or 0.030 in.

Replace spark plugs every season. Spark tester and spark plug wrench are available from any Authorized Briggs & Stratton Service Dealer.

Note: In some areas, local law requires using a resistor spark plug to suppress ignition signals. If this engine was originally equipped with resistor spark plug, use same type of spark plug for replacement.

Maintenance Cont'd

Air cleaner, dual element

Replace pre-cleaner or cartridge if very dirty or damaged. To service pre-cleaner, wash in liquid detergent and water. Squeeze dry in a clean cloth. Saturate in engine oil. Squeeze in clean, absorbent cloth to remove excess oil.

1. See illustrations (see fig. [8]) for disassembly and reassembly of your air cleaner style.
2. Carefully remove air cleaner cartridge and pre-cleaner, preventing debris from entering carburetor.
3. Install pre-cleaner (if equipped) in base with mesh side up.
4. Install cartridge on pre-cleaner.
5. Replace cover. To ensure proper fit, tabs must be hooked into slots. Tabs are painted a different color in some instances.
6. Latch handle or tighten knobs completely to secure cover.

CAUTION: Improper installation of air cleaner cover may cause damage to engine.

EXTENDED LIFE SERIES™ CARTRIDGE ONLY

This filter, IF STAMPED 'WASHABLE', can be washed with mild soap in warm water. **IMPORTANT:** Rinse in tap water with **SCREEN** side up allowing dirt and debris to filter out. Leave filter to dry overnight before reinstalling.



Keep engine clean (see fig. [9])

Periodically remove grass/chaff buildup from engine. Do not spray engine with water because water could contaminate fuel. Use a brush or compressed air.



Accumulation of debris around exhaust manifold/muffler ④ could cause a fire. Inspect and clean before every use.

Keep linkage, springs and controls ④ free of debris.

If muffler is equipped with spark arrester screen, remove spark arrester screen for cleaning and inspection every 50 hours or every season. Replace if damaged.



Replace in-line fuel filter ⑤ every season. Drain fuel tank or close fuel shut-off valve before replacing filter.

Grass or chaff may clog engine's air cooling system, especially after prolonged service cutting tall, dry grass. Every 100 hours or every season remove rotating screen, air cleaner cover and blower housing ⑥ to clean internal cooling fins and surfaces to prevent overheating and engine damage. To prevent debris from entering carburetor, it is important to cover the carburetor air intake ⑦ located above and behind carburetor (inset) when cleaning cooling system.

Check valve clearance (intake and exhaust .10-.15mm)

Maintenance Schedule

Follow the hourly or calendar intervals, whichever occur first. More frequent service is required when operating in adverse conditions noted below.

First 8 Hours

- Change oil

Every 8 hours or daily

- Check oil level
- Clean around muffler, linkage and springs

Every 25 hours or every season

- Change oil if operating under heavy load or high ambient temperature
- Replace air cleaner pre-cleaner*

Every 50 hours or every season

- Change oil
- Clean Extended Life Series™ air cleaner cartridge.*
- Clean and inspect spark arrester, if equipped

Every 100 hours or every season

- Service air cleaner cartridge*
- Replace oil filter, if equipped
- Clean cooling system*

Every 200 hours or every season

- Replace Extended Life Series™ air cleaner cartridge*

Every season

- Replace spark plugs
- Replace in-line fuel filter
- Check valve clearance

* *Clean more often under dusty conditions, or when airborne debris is present or after prolonged operation cutting tall, dry grass.*

Partial List of Genuine Briggs & Stratton Parts

Part	Part No.
Oil (20 oz.)	100005
Oil (48 oz.)	100028
Extended Life Series™ Oil filter	696854
Oil filter (6 cm long)	492932 -or- 5049
Oil pump kit (uses standard electric drill to remove oil from engine quickly)	5056
Fuel stabilizer (1 oz., 30 ml single use pouch)	992030
Fuel stabilizer (4.2 oz., 125 ml bottle)	5041
Fuel filter	493629
Oval Air cleaner cartridge	792105
Extended Life Series™ air cleaner cartridge	695667
Air cleaner cartridge	499486
Air cleaner pre-cleaner	273638
Resistor spark plug	691043 -or- 491055
Long life platinum spark plug (used on most OHV engines)	5066
Spark tester	19368
Spark plug wrench	19374

Storage

Engines stored over 30 days need to be protected or drained of fuel to prevent gum from forming in fuel system or on essential carburetor parts.

For engine protection, we recommend use of Briggs & Stratton Fuel Stabilizer available from an Authorized Briggs & Stratton Service Dealer. Mix stabilizer with fuel in fuel tank or storage container. Run engine for a short time to circulate stabilizer through carburetor. Engine and fuel can be stored up to 24 months.

Note: If stabilizer is not used or if engine is operating on gasoline containing alcohol, e.g. gasohol, remove all fuel from tank and run engine until it stops from lack of fuel.

1. Change oil. See **Oil service.** (see figs. 2 7)
2. Remove spark plugs and pour about 30 ml (1 oz) of engine oil into cylinders. Replace spark plugs and crank slowly to distribute oil.
3. Clean grass/chaff from cylinders and cylinder head fins and behind muffler.
4. Store in a clean and dry area, but NOT near a stove, furnace or water heater which uses a pilot light or any device that can create a spark.

Service

See an Authorized Briggs & Stratton Service Dealer. Each one carries a stock of Genuine Briggs & Stratton Parts and is equipped with special service tools. Trained mechanics assure expert repair service on all Briggs & Stratton engines. Only dealers advertising as "Authorized Briggs & Stratton" are required to meet Briggs & Stratton standards.

When you purchase equipment powered by a Briggs & Stratton engine, you are assured of highly skilled, reliable service at more than 30,000 Authorized Service Dealers worldwide, including more than 6,000 Master Service Technicians. Look for these signs wherever Briggs & Stratton service is offered.



You may locate your nearest Authorized Briggs & Stratton Service Dealer in our dealer locator map on our web site www.briggsandstratton.com or in the "Yellow

Pages™" directory under "Engines, Gasoline" or "Gasoline Engines," or "Lawn Mowers" or similar category.



Note: Walking fingers logo and "Yellow Pages" are registered trademarks in various jurisdictions.

An illustrated shop manual includes "Theories of Operation," common specifications and detailed information covering adjustment, tune-up and repair of Briggs & Stratton V-twin cylinder OHV, 4 cycle engines. Order P/N 273521 from an Authorized Briggs & Stratton Service Dealer.

Insist on Genuine Briggs & Stratton replacement parts with our logo on the box and/or part. Non-original parts may not perform as well and may void your warranty.

**Briggs & Stratton Corporation (B&S),
the California Air Resources Board (CARB)
and the United States
Environmental Protection Agency (U.S. EPA)
Emissions Control System Warranty Statement
(Owner's Defect Warranty Rights and Obligations)**

California, United States and Canada Emissions Control Defects Warranty Statement

The California Air Resources Board (CARB), U.S. EPA and B&S are pleased to explain the Emissions Control System Warranty on your small off-road engine (SORE). In California, new small off-road engines model year 2006 and later must be designed, built and equipped to meet the State's stringent anti-smog standards. Elsewhere in the United States, new non-road, spark-ignition engines certified for model year 1997 and later must meet similar standards set forth by the U.S. EPA. B&S must warrant the emissions control system on your engine for the periods of time listed below, provided there has been no abuse, neglect or improper maintenance of your small off-road engine. Your emissions control system includes parts such as the carburetor, air cleaner, ignition system, fuel line, muffler and catalytic converter. Also included may be connectors and other emissions related assemblies. Where a warrantable condition exists, B&S will repair your small off-road engine at no cost to you including diagnosis, parts and labor.

Briggs & Stratton Emissions Control Defects Warranty Coverage

Small off-road engines are warranted relative to emissions control parts defects for a period of two years, subject to provisions set forth below. If any covered part on your engine is defective, the part will be repaired or replaced by B&S.

Owner's Warranty Responsibilities

As the small off-road engine owner, you are responsible for the performance of the required maintenance listed in your Operating and Maintenance Instructions. B&S recommends that you retain all your receipts covering maintenance on your small off-road engine, but B&S cannot deny warranty solely for the lack of receipts or for your failure to ensure the performance of all scheduled maintenance.

As the small off-road engine owner, you should however be aware that B&S may deny you warranty coverage if your small off-road engine or a part has failed due to abuse, neglect, improper maintenance or unapproved modifications.

You are responsible for presenting your small off-road engine to an Authorized B&S Service Dealer as soon as a problem exists. The undisputed warranty repairs should be completed in a reasonable amount of time, not to exceed 30 days.

If you have any questions regarding your warranty rights and responsibilities, you should contact a B&S Service Representative at 1-414-259-5262.

The emissions warranty is a defects warranty. Defects are judged on normal engine performance. The warranty is not related to an in-use emissions test.

Briggs & Stratton Emissions Control Defects Warranty Provisions

The following are specific provisions relative to your Emissions Control Defects Warranty Coverage. It is in addition to the B&S engine warranty for non-regulated engines found in the Operating and Maintenance Instructions.

1. Warranted Parts

Coverage under this warranty extends only to the parts listed below (the emissions control systems parts) to the extent these parts were present on the engine purchased.

- a. Fuel Metering System
 - Cold start enrichment system (soft choke)
 - Carburetor and internal parts
 - Fuel pump
 - Fuel line, fuel line fittings, clamps
 - Fuel tank, cap and tether
 - Carbon canister
- b. Air Induction System
 - Air cleaner
 - Intake manifold
 - Purge and vent line
- c. Ignition System
 - Spark plug(s)
 - Magneto ignition system
- d. Catalyst System
 - Catalytic converter
 - Exhaust manifold
 - Air injection system or pulse valve
- e. Miscellaneous Items Used in Above Systems
 - Vacuum, temperature, position, time sensitive valves and switches
 - Connectors and assemblies

2. Length of Coverage

B&S warrants to the initial owner and each subsequent purchaser that the Warranted Parts shall be free from defects in materials and workmanship which caused the failure of the Warranted Parts for a period of two years from the date the engine is delivered to a retail purchaser.

3. No Charge

Repair or replacement of any Warranted Part will be performed at no charge to the owner, including diagnostic labor which leads to the determination that a Warranted Part is defective, if the diagnostic work is performed at an Authorized B&S Service Dealer. For emissions warranty service contact your nearest Authorized B&S Service Dealer as listed in the "Yellow Pages" under "Engines, Gasoline," "Gasoline Engines," "Lawn Mowers," or similar category.

4. Claims and Coverage Exclusions

Warranty claims shall be filed in accordance with the provisions of the B&S Engine Warranty Policy. Warranty coverage shall be excluded for failures of Warranted Parts which are not original B&S parts or because of abuse, neglect or improper maintenance as set forth in the B&S Engine Warranty Policy. B&S is not liable to cover failures of Warranted Parts caused by the use of add-on, non-original, or modified parts.

5. Maintenance

Any Warranted Part which is not scheduled for replacement as required maintenance or which is scheduled only for regular inspection to the effect of "repair or replace as necessary" shall be warranted as to defects for the warranty period. Any Warranted Part which is scheduled for replacement as required maintenance shall be warranted as to defects only for the period of time up to the first scheduled replacement for that part. Any replacement part that is equivalent in performance and durability may be used in the performance of any maintenance or repairs. The owner is responsible for the performance of all required maintenance, as defined in the B&S Operating and Maintenance Instructions.

6. Consequential Coverage

Coverage hereunder shall extend to the failure of any engine components caused by the failure of any Warranted Part still under warranty.

Look For Relevant Emissions Durability Period and Air Index Information On Your Engine Emissions Label

Engines that are certified to meet the California Air Resources Board (CARB) Tier 2 Emissions Standards must display information regarding the Emissions Durability Period and the Air Index. Briggs & Stratton makes this information available to the consumer on our emissions labels. The engine emission label will indicate certification information.

The **Emissions Durability Period** describes the number of hours of actual running time for which the engine is certified to be emissions compliant, assuming proper maintenance in accordance with the Operating & Maintenance Instructions. The following categories are used:

Moderate:

Engine is certified to be emissions compliant for 125 hours of actual engine running time.

Intermediate:

Engine is certified to be emissions compliant for 250 hours of actual engine running time.

Extended:

Engine is certified to be emissions compliant for 500 hours of actual engine running time. For example, a typical walk-behind lawn mower is used 20 to 25 hours per year. Therefore, the **Emissions Durability Period** of an engine with an **intermediate** rating would equate to 10 to 12 years.

Certain Briggs & Stratton engines will be certified to meet the United States Environmental Protection Agency (USEPA) Phase 2 emission standards. For Phase 2 certified engines, the Emissions Compliance Period referred to on the Emissions Compliance label indicates the number of operating hours for which the engine has been shown to meet Federal emission requirements.

For engines less than 225 cc displacement.

Category C = 125 hours

Category B = 250 hours

Category A = 500 hours

For engines of 225 cc or more displacement.

Category C = 250 hours

Category B = 500 hours

Category A = 1000 hours.

BRIGGS & STRATTON ENGINE OWNER WARRANTY POLICY

Effective September 1, 2006

LIMITED WARRANTY

Briggs & Stratton Corporation will repair or replace, free of charge, any part(s) of the engine that is defective in material or workmanship or both. Transportation charges on parts submitted for repair or replacement under this warranty must be borne by purchaser. This warranty is effective for and is subject to the time periods and conditions stated below. For warranty service, find the nearest Authorized Service Dealer in our dealer locator map at www.briggsandstratton.com, or by calling 1-800-233-3723, or as listed in the "Yellow Pages™".

THERE IS NO OTHER EXPRESS WARRANTY. IMPLIED WARRANTIES, INCLUDING THOSE OF MERCHANTABILITY AND FITNESS FOR A PARTICULAR PURPOSE, ARE LIMITED TO ONE YEAR FROM PURCHASE, OR TO THE EXTENT PERMITTED BY LAW ANY AND ALL IMPLIED WARRANTIES ARE EXCLUDED. LIABILITY FOR INCIDENTAL OR CONSEQUENTIAL DAMAGES ARE EXCLUDED TO THE EXTENT EXCLUSION IS PERMITTED BY LAW. Some states or countries do not allow limitations on how long an implied warranty lasts, and some states or countries do not allow the exclusion or limitation of incidental or consequential damages, so the above limitation and exclusion may not apply to you. This warranty gives you specific legal rights and you may also have other rights which vary from state to state and country to country.

WARRANTY TERMS **

Brand/Product Type	Consumer Use	Commercial Use
Vanguard™	2 years	2 years
Extended Life Series™	2 years	1 year
I/C®, Intek I/C®, Intek Pro™	2 years	180 days
Kerosene Fuel Operated Engines	1 year	90 days
All Other Briggs & Stratton Engines	2 years	90 days

** Engines used on Home Standby Generator applications are warranted under consumer use only. This warranty does not apply to engines on equipment used for prime power in place of a utility. Engines used in competitive racing or on commercial or rental tracks are not warranted.

The warranty period begins on the date of purchase by the first retail consumer or commercial end user, and continues for the period of time stated in the table above. "Consumer use" means personal residential household use by a retail consumer. "Commercial use" means all other uses, including use for commercial, income producing or rental purposes. Once an engine has experienced commercial use, it shall thereafter be considered as a commercial use engine for purposes of this warranty.

NO WARRANTY REGISTRATION IS NECESSARY TO OBTAIN WARRANTY ON BRIGGS & STRATTON PRODUCTS. SAVE YOUR PROOF OF PURCHASE RECEIPT. IF YOU DO NOT PROVIDE PROOF OF THE INITIAL PURCHASE DATE AT THE TIME WARRANTY SERVICE IS REQUESTED, THE MANUFACTURING DATE OF THE PRODUCT WILL BE USED TO DETERMINE THE WARRANTY PERIOD.

ABOUT YOUR ENGINE WARRANTY

Briggs & Stratton welcomes warranty repair and apologizes to you for being inconvenienced. Any Authorized Service Dealer may perform warranty repairs. Most warranty repairs are handled routinely, but sometimes requests for warranty service may not be appropriate. For example, warranty would not apply if engine damage occurred because of misuse, lack of routine maintenance, shipping, handling, warehousing or improper installation. Similarly, warranty is void if the serial number of the engine has been removed or the engine has been altered or modified.

If a customer differs with the decision of the Service Dealer, an investigation will be made to determine whether the warranty applies. Ask the Service Dealer to submit all supporting facts to his Distributor or the Factory for review. If the Distributor or the Factory decides that the claim is justified, the customer will be fully reimbursed for those items that are defective. To avoid misunderstanding which might occur between the customer and the Dealer, listed below are some of the causes of engine failure that the warranty does not cover.

Normal wear:

Engines, like all mechanical devices, need periodic parts service and replacement to perform well. Warranty will not cover repair when normal use has exhausted the life of a part or an engine.

Improper maintenance:

The life of an engine depends upon the conditions under which it operates, and the care it receives. Some applications, such as tillers, pumps and rotary mowers, are very often used in dusty or

dirty conditions, which can cause what appears to be premature wear. Such wear, when caused by dirt, dust, spark plug cleaning grit, or other abrasive material that has entered the engine because of improper maintenance, is not covered by warranty.

This warranty covers engine related defective material and/or workmanship only, and not replacement or refund of the equipment to which the engine may be mounted. Nor does the warranty extend to repairs required because of:

1. PROBLEMS CAUSED BY PARTS THAT ARE NOT ORIGINAL BRIGGS & STRATTON PARTS.
2. Equipment controls or installations that prevent starting, cause unsatisfactory engine performance, or shorten engine life. (Contact equipment manufacturer.)
3. Leaking carburetors, clogged fuel pipes, sticking valves, or other damage, caused by using contaminated or stale fuel. (Use clean, fresh, lead-free gasoline and Briggs & Stratton Fuel Stabilizer, Part No. 5041.)
4. Parts which are scored or broken because an engine was operated with insufficient or contaminated lubricating oil, or an incorrect grade of lubricating oil. OIL GARD may not shut down running engine. Engine damage may occur if oil level is not properly maintained.
5. Repair or adjustment of associated parts or assemblies such as clutches, transmissions, remote controls, etc., which are not manufactured by Briggs & Stratton.
6. Damage or wear to parts caused by dirt, which entered the engine because of improper air cleaner maintenance,

re-assembly, or use of a non-original air cleaner element or cartridge.

7. Parts damaged by over-speeding, or overheating caused by grass, debris, or dirt, which plugs or clogs the cooling fins, or flywheel area, or damage caused by operating the engine in a confined area without sufficient ventilation.
8. Engine or equipment parts broken by excessive vibration caused by a loose engine mounting, loose cutter blades, unbalanced blades or loose or unbalanced impellers, improper attachment of equipment to engine crankshaft, over-speeding or other abuse in operation.
9. A bent or broken crankshaft, caused by striking a solid object with the cutter blade of a rotary lawn mower, or excessive v-belt tightness.
10. Routine tune-up or adjustment of the engine.
11. Engine or engine component failure, i.e., combustion chamber, valves, valve seats, valve guides, or burned starter motor windings, caused by the use of alternate fuels such as, liquified petroleum, natural gas, altered gasolines, etc.

Warranty is available only through service dealers which have been authorized by Briggs & Stratton Corporation. your nearest Authorized Service Dealer is listed in the "Yellow Pages™" of your telephone directory under "Engines, Gasoline" or "Gasoline Engines," "Lawn Mowers," or similar category.

Briggs & Stratton Engines Are Made Under One Or More Of The Following Patents: Design D-247,177 (Other Patents Pending)										
6,691,683	6,520,141	6,325,036	6,145,487	6,012,420	5,803,035	5,548,955	5,243,878	5,138,996	4,875,448	D 476,629
6,647,942	6,495,267	6,311,663	6,142,257	5,992,367	5,765,713	5,546,901	5,235,943	5,086,890	4,819,593	D 457,891
6,622,683	6,494,175	6,284,123	6,135,426	5,904,124	5,732,555	5,445,014	5,234,038	5,070,829	4,720,638	D 368,187
6,615,787	6,472,790	6,263,852	6,116,212	5,894,715	5,645,025	5,503,125	5,228,487	5,058,544	4,719,682	D 375,963
6,617,725	6,460,502	6,260,529	6,105,548	5,887,678	5,642,701	5,501,203	5,197,426	5,040,644	4,633,556	D 309,457
6,603,227	6,456,515	6,242,828	6,347,614	5,852,951	5,628,352	5,497,679	5,197,425	5,009,208	4,630,498	D 372,871
6,595,897	6,382,166	6,239,709	6,082,323	5,843,345	5,619,845	5,320,795	5,197,422	4,996,956	4,522,080	D 361,771
6,595,176	6,369,532	6,237,555	6,077,063	5,823,153	5,606,948	5,301,643	5,191,864	4,977,879	4,520,288	D 356,951
6,584,964	6,356,003	6,230,678	6,064,027	5,819,513	5,606,851	5,271,363	5,188,069	4,977,877	4,512,499	D 309,457
6,557,833	6,349,688	6,213,083	6,040,767	5,813,384	5,605,130	5,269,713	5,186,142	4,971,219	4,453,507	D 308,872
6,542,074	6,347,614	6,202,616	6,014,808	5,809,958	5,497,679	5,265,700	5,150,674	4,895,119	4,430,984	D 308,871

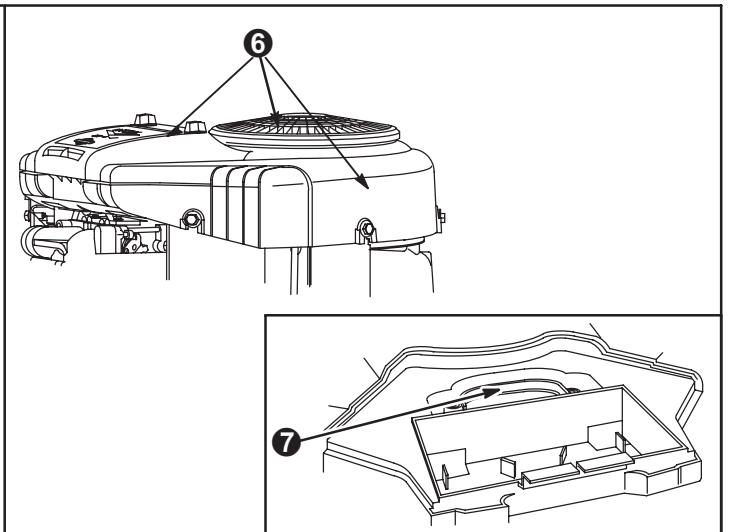
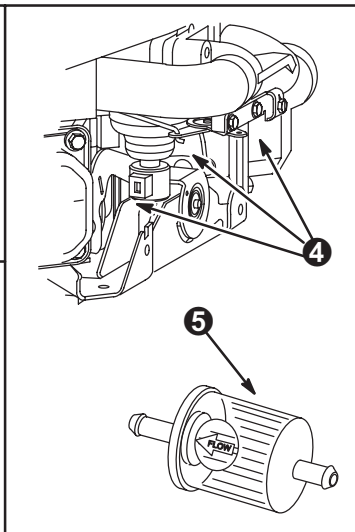
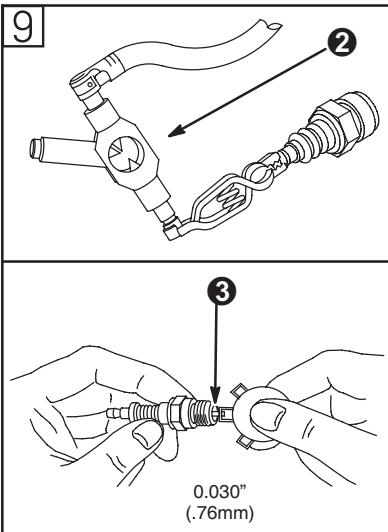
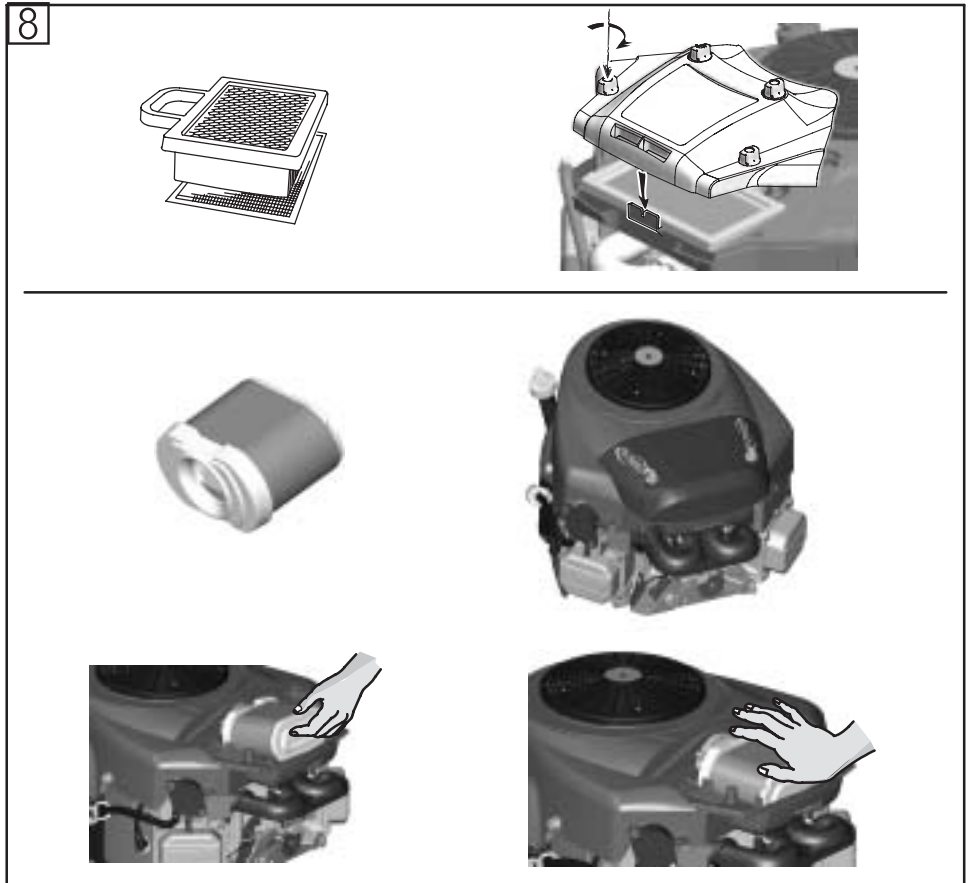
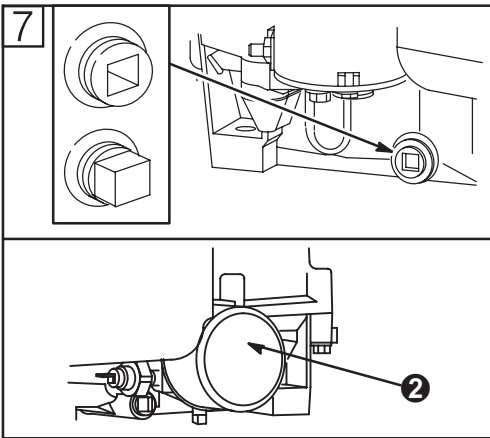
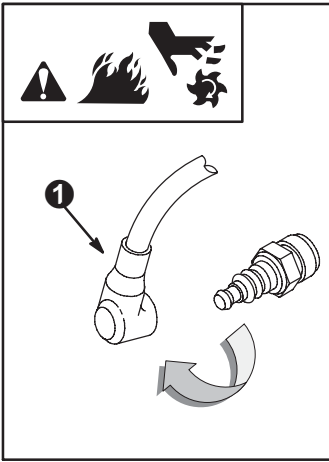



THE POWER WITHIN™